

pe:etron

Discover Bulkmatology®
The Nature of Bulk Material Handling

DeDuster® Anthology – The Complete Guide





Mobile DeDuster® in a silofarm

Contents

	PAGE
Following Nature’s Lead	4
Where Do Fines Come From and Why is Cleaning So Important?	5
The Pelletron DeDuster® – The Ultimate Cleaning Technology	6
DeDuster® Applications for the Plastics Processing Industry	7
DeDuster® Applications for the Plastics Manufacturing and Compounding Industry	8
DeDuster® Applications for Other Industries. How Versatile is the DeDuster®?	9
Systems Configurations	10
Selecting the Right Dedusting System	12
Dedusting Test Facilities	13
Research & Development	13
DeDuster® Product Line	14
Pelletron DeDuster® Systems are Installed All Over the World	16

Following Nature's Lead

Purity of material was the driving force behind the development of separation technologies. It began thousands of years ago with the need to clean grain, corn, rice and other foods, a task that was accomplished with the aid of a simple stream of air. Over the centuries, the desire for efficiency resulted in new inventions all designed to improve the cleaning and separation processes. Our modern day machine cleaning technology is based on this same concept of separation with air.



In order to build an understanding of the technology of cleaning or “dedusting” materials, let us first take a look at history. After the most basic cleaning method of simply tossing the material into the air and letting air and gravity do the work, the need to improve efficiency resulted in other innovations. The “scalperator” was a separation machine that removed hulls from grains.

Later, the “aspirator” was used. Its cleaning principle is based on air blowing perpendicular to the material flow. This was an efficiency improvement, one that is still useful in industries with lower cleaning efficiency requirements like agriculture, among others.

The requirement for higher cleaning efficiency continued and, in the 1970s and 1980s, the plastics industry began to drive demand. The need for better quality resulted in the development of the “elutriator.” This technology was focused on the cleaning of pellets at the end of a dilute phase conveying line. Because of its working principle, an elutriator was typically installed on top of a silo or before a silo farm, where the distribution of pellets to the storage silos is done after cleaning. Because its principal of cleaning is based on counterflow, the elutriator does not remove long streamers, also called “angel hair”, so it was often combined with a drum sieve. The graphics on the next page illustrate the counterflow principle and a typical elutriator installation at a silo farm.

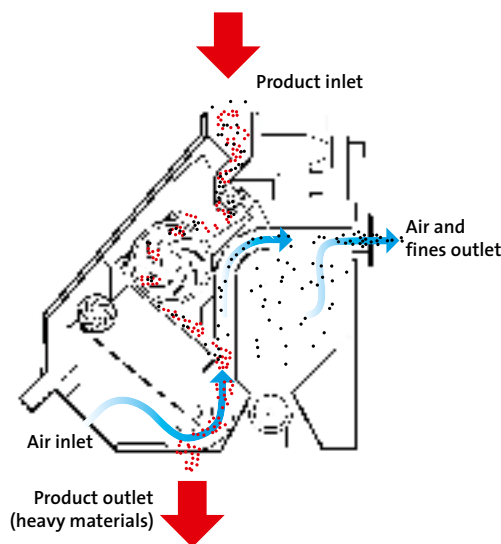

Scalperator

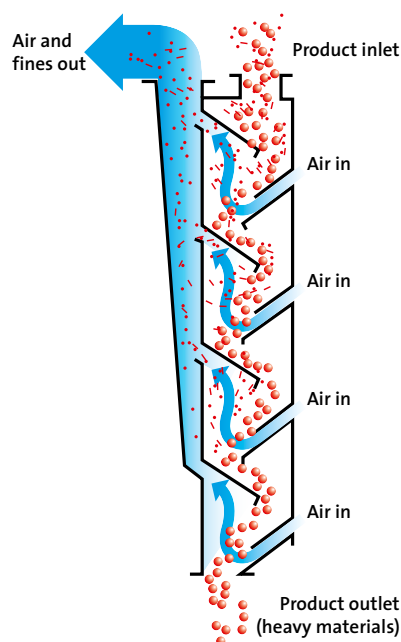

Aspirator



System with Elutriator

Many more separation and cleaning machines were marketed to address specific application requirements. There were separators with bottom entry and separators with rotating discs, among others. As efficiency demands increased, the dedusting technology emerged as a solution that provided superior results when cleaning all kinds of bulk solid materials. As technology evolved further, the Pelletron DeDuster® emerged as the most efficient way to remove all kinds of dust, streamers and other contaminants. For a better understanding of fines creation and modern fines removal, let us take a closer look.

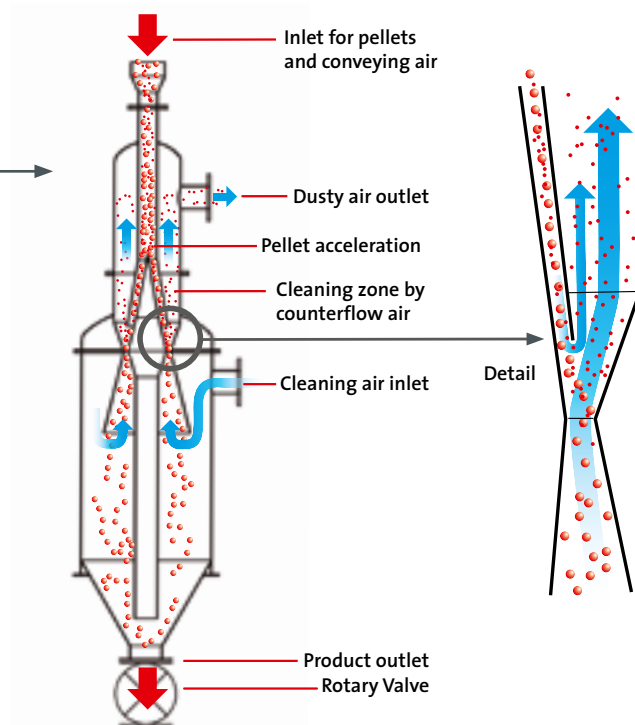

Elutriator

Where Do Fines Come From and Why Is Cleaning So Important?

Some dust and contaminants occur naturally in products like minerals, food, tablets and other bulk solids, while others are caused by the way the products are handled. Impurities in plastic pellets, both fines (dust) and angel hair (streamers), are generated by the friction in conveying lines. Dilute phase systems create large amounts of dust and streamers; the higher the velocity, the larger the amount of impurities. Pipe elbows also cause friction and result in the creation of more dust and streamers. The high pressure in dense phase, or slow motion systems, creates very fine dust due to wall friction and friction between pellets. Temperature, pellet shape and product characteristics can also contribute to the creation of dust.

Cleaning bulk solids is important for a number of reasons. Food and pharmaceutical bulk solids are cleaned for hygienic reasons and to improve the quality of the finished, packaged product. Minerals are cleaned primarily to avoid environmental and health problems. The plastics industry cleans pellets to improve the quality of both the pellets and the finished plastic product.

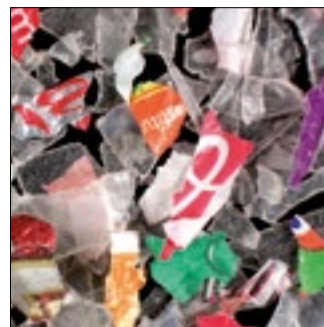

The Pelletron DeDuster® – The Ultimate Cleaning Technology

The Pelletron DeDuster® was developed as a result of demands for high quality standards in the plastics industry, but the technology can be used for all kinds of granular bulk materials. The list of requirements for a new, universal dedusting machine was long:

- Remove dust and streamers with one machine
- Separate and remove electro-statically charged dust particles
- Fit on injection molding machines
- Offer low construction height
- Fit on top of extruders and under silos
- Reduce remaining dust level after cleaning to <50PPM

To address this list of requirements, Pelletron developed a cleaning machine that combines a variety of air wash principles, plus the revolutionary electro-static flux field feature, and built it with the lowest possible construction height. When charged particles enter into the Magnetic Flux Field, the resulting “Lorentz Force” weakens the electro-static bond between fine dust and plastic pellets. This weakening, in combination with the air flow, allows the micro fine particles attracted to the pellet surfaces to be removed.

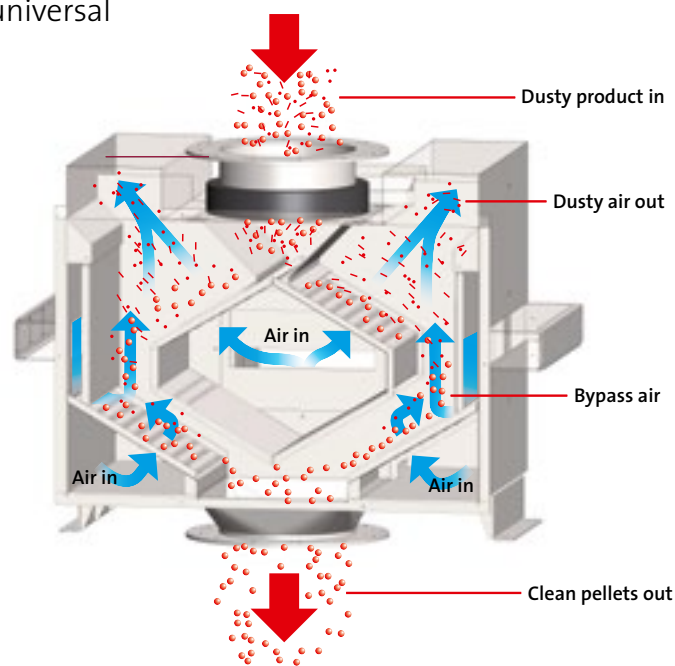

The Pelletron DeDuster®

The specially designed slot and hole pattern in the air wash deck creates a fluidization effect, another advantage of the Pelletron DeDuster®. For removing large particles and streamers, an adjustable Venturi Zone was designed. Adjustment of the Venturi Zone width, in combination with the regulation of the bypass airflow, allows a perfect separation of streamers from good product. This special air wash effect also removes the heavier particles such as paper, metal parts < 300 micron and other contaminants. The airflow in the DeDuster® creates negative pressure at the DeDuster® outlet.

All DeDuster® systems are equipped with a window made of either polycarbonate or glass. Optionally, a stainless steel door with windows can be supplied for high temperature applications. The DeDuster® can also be operated in inert gas environments such as N₂-systems. In situations where a DeDuster® is installed before or after a conveying system, the DeDuster® inlet or outlet needs to be separated by a rotary valve.

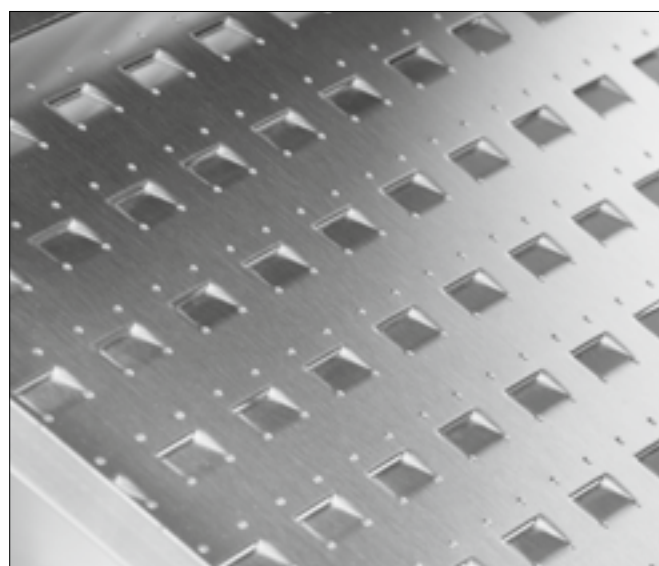

Patented wash deck design, used for all DeDusters®

DeDuster® Applications for the Plastics Processing Industry

Production of high quality end products requires clean plastic pellets. Dust and streamers in plastic pellets cause many problems for the plastics processing industry:

- High “scrap” rates from fines burning in mold
- Blurry surfaces resulting from vaporized dust particles
- Weak spots in fibers
- Flaws in wire insulation
- Gels in films
- Housekeeping problems caused by dust and streamers
- Crusting of feed throat of screw
- Reduced mold and screw life resulting from carbonization of dust
- Mold vents clogged by dust
- Equipment and machines clogged by streamers
- Dust accumulation on silo walls, roofs and hopper walls

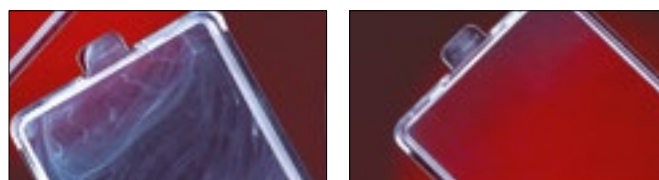

Problems caused by dust

A DeDuster® can be installed directly on top of an injection molding machine or on a dryer, depending on the process requirements. The standard installation is a closed loop configuration with a fan and a dust collector. The removed dust is separated by the dust collector and dropped into a dust bucket, and the cleaned air is returned to the DeDuster®. Special configurations for clean room applications are also available.



Regrind is also common in the plastics processing industry. Regrind is very dusty and needs to be cleaned before it is mixed with virgin pellets, before packaging into big bags or re-pelletizing.



High quality end product

The DeDuster® for injection molders

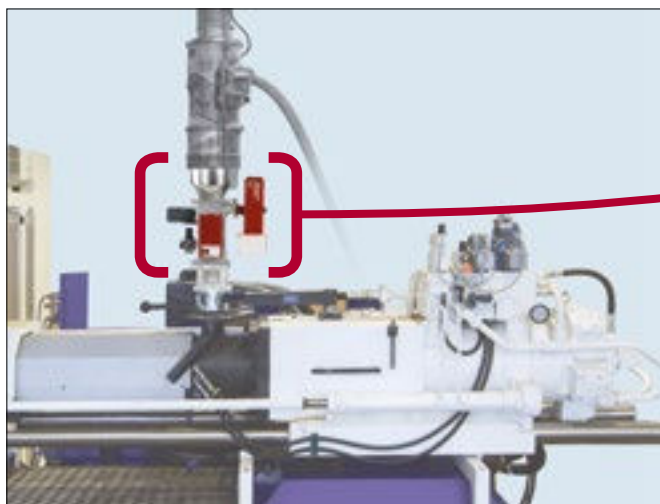

C-20 DeDuster® installed on injection molding machine (IMM)

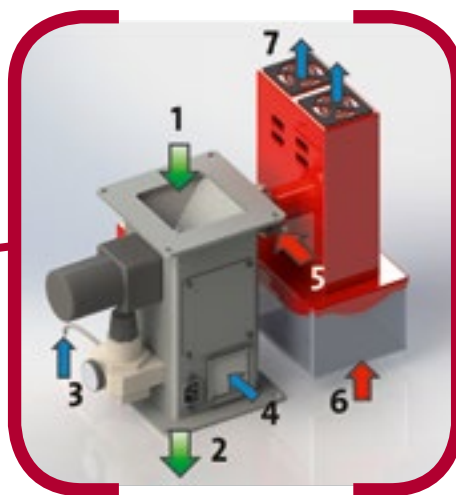

- 1 Untreated Product 2 Cleaned Product
3 Compressed Air Supply 4 Fresh Air Inlet (Filtered)
5 Dirty Air 6 Dust & Streamers 7 Outlet Air (Filtered)

DeDuster® Applications for the Plastics Manufacturing and Compounding Industry

Clean pellets, without dust or streamers, are the goal of every plastic manufacturing company. The most effective use of a DeDuster® is to position it under storage silos, for use before packaging. Installation at this position allows for the efficient removal of any dust and streamers that have accumulated in the silos, including the impurities created by dust surges.

Many existing pneumatic conveying systems are equipped with older technology dust removal systems, such as scalpators, aspirators and elutriators. These systems cannot provide the cleaning results required by modern manufacturing plants. For most applications, a Pelletron DeDuster® can be added under silos, before packaging, to improve the results. Pelletron has developed models that fit on bagging machines or can be moved between silos where a silo farm is in use. Because of its ability to remove the micro fine, high electrostatically charged dust particles characteristic of dense phase systems, retrofitting existing systems with a DeDuster® has become common practice. The flow sheet below shows examples of various solutions for the installation of DeDuster® systems under silos.



XP540 mobile DeDuster® combined with bagging station



3D model of mobile DeDuster® installed on bagging machine



DeDuster® in operation

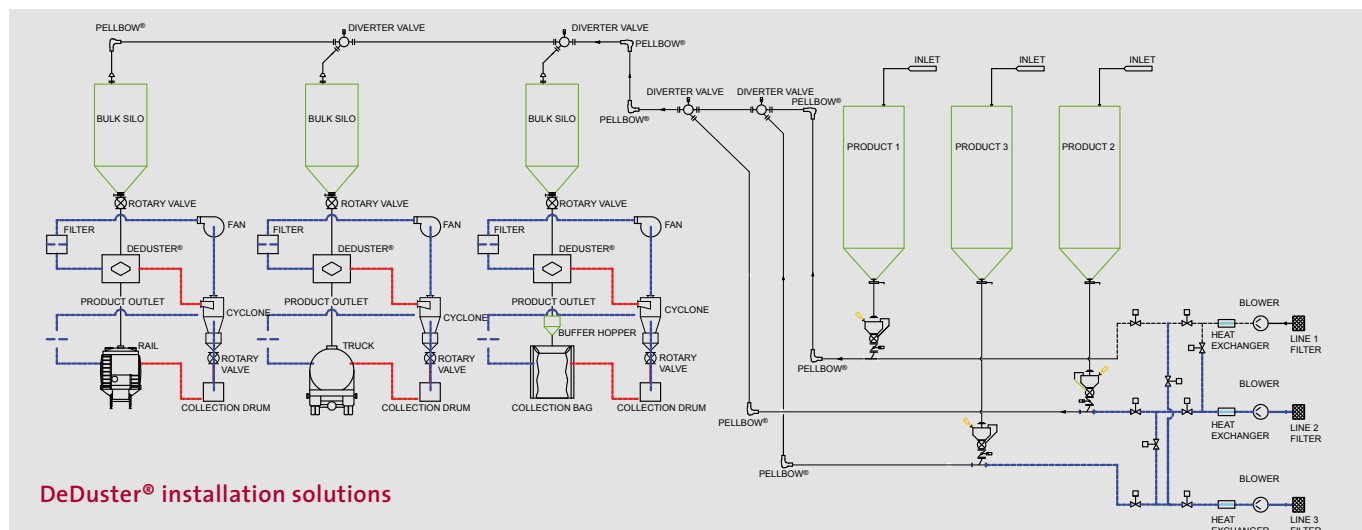

DeDuster® installation solutions



DeDuster® Applications for Other Industries How Versatile is the DeDuster®?

Pelletron has developed several solutions to address unique customer applications. Besides the cleaning of plastic pellets, the DeDuster® can be used for cleaning dry bulk solids in the food, mineral and pharmaceutical industries. Some examples for materials that require cleaning are:

- Rice, corn, peanuts, coffee beans
- Iron ore, special sand, wood pellets
- Tablets, pills
- And many more...

Removal of dust is often necessary because of the environmental challenge it creates. Pelletron developed a special, wear-resistant DeDuster® for cleaning iron ore to address the health concerns associated with iron ore dust in the air and to save energy by reducing the dust that hinders the melting process.

Our standard DeDuster® systems have capacities ranging from a few pounds (kilograms) up to 200,000lbs (100 tons). For applications that require higher capacities, Pelletron has built custom models capable of processing several hundred tons per hour. For installations with inclined silo outlet pipes, the OS-DeDuster® (**OffSet**) was developed. For narrow packaging lines, the DO-DeDuster® (single inlet and **Dual Outlet**) was designed. Pelletron also provides wash down DeDuster® systems designed for cleaning with water between product changes. Pelletron continues to respond to customer requests for unique applications.



DeDuster® for cleaning iron ore pellets



Fan for iron ore cleaning

Systems Configurations

Open loop dedusting system with cyclone

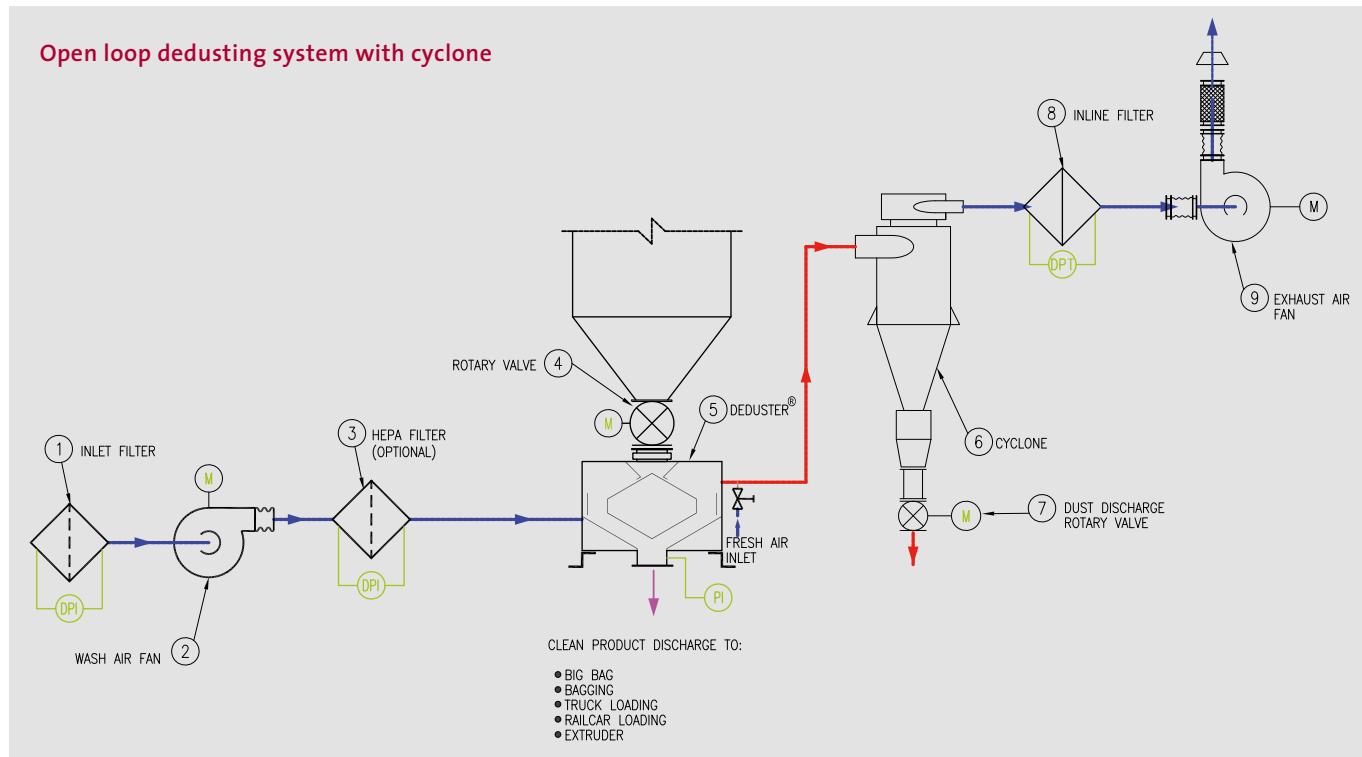

An open loop system is recommended for processes with frequent product changes or for lines with frequent color changes in order to avoid cross contamination. Filtered fresh air is pushed from a wash air fan into the DeDuster® supplying the cleaning air. A second exhaust air fan pulls the dusty air into a cyclone or baghouse dust collector. The dust is separated in a dust collector and dropped into the dust container. The cleaned air is then released into the atmosphere.

A closed loop system is recommended for standard operations with the same or similar product grades or for inert gas applications. A push/pull wash air fan supplies the wash air and pushes it into the DeDuster®. The dust is separated by the baghouse dust collector and dropped into a dust container. The cleaned air is returned to the fan.

Open loop dedusting system with baghouse filter

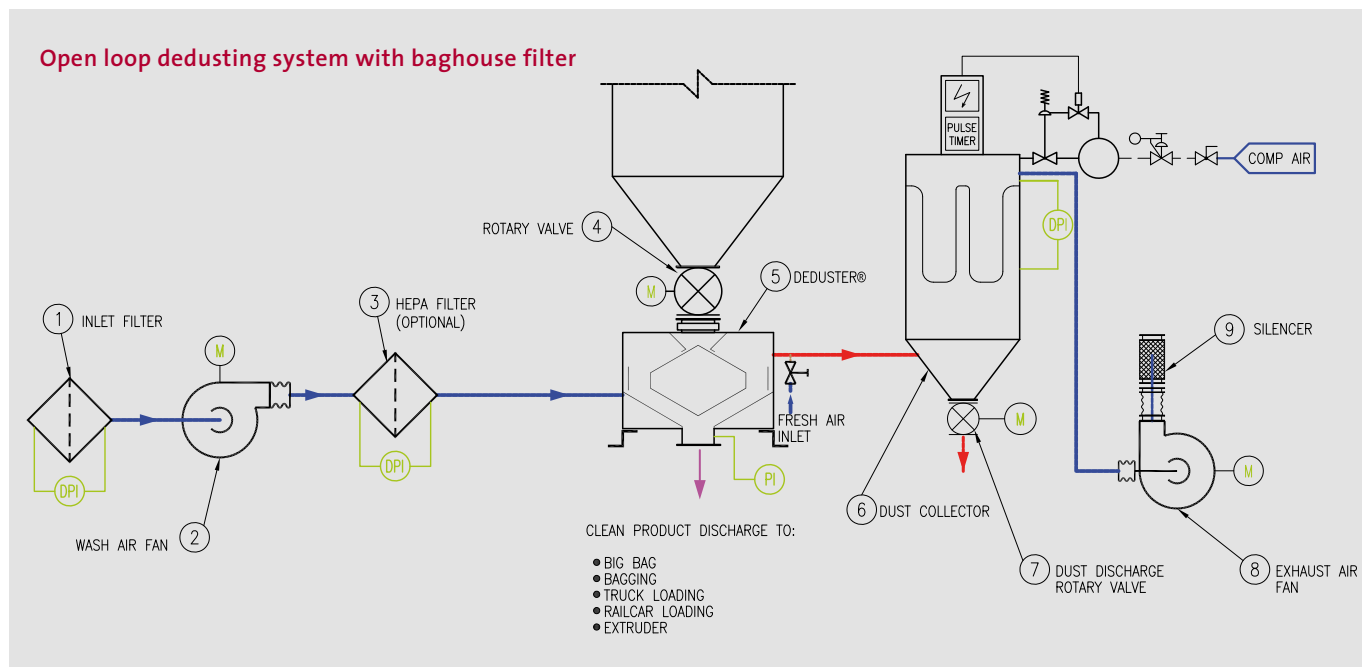

**Closed loop dedusting system
with cyclone CCD-system (patented)**

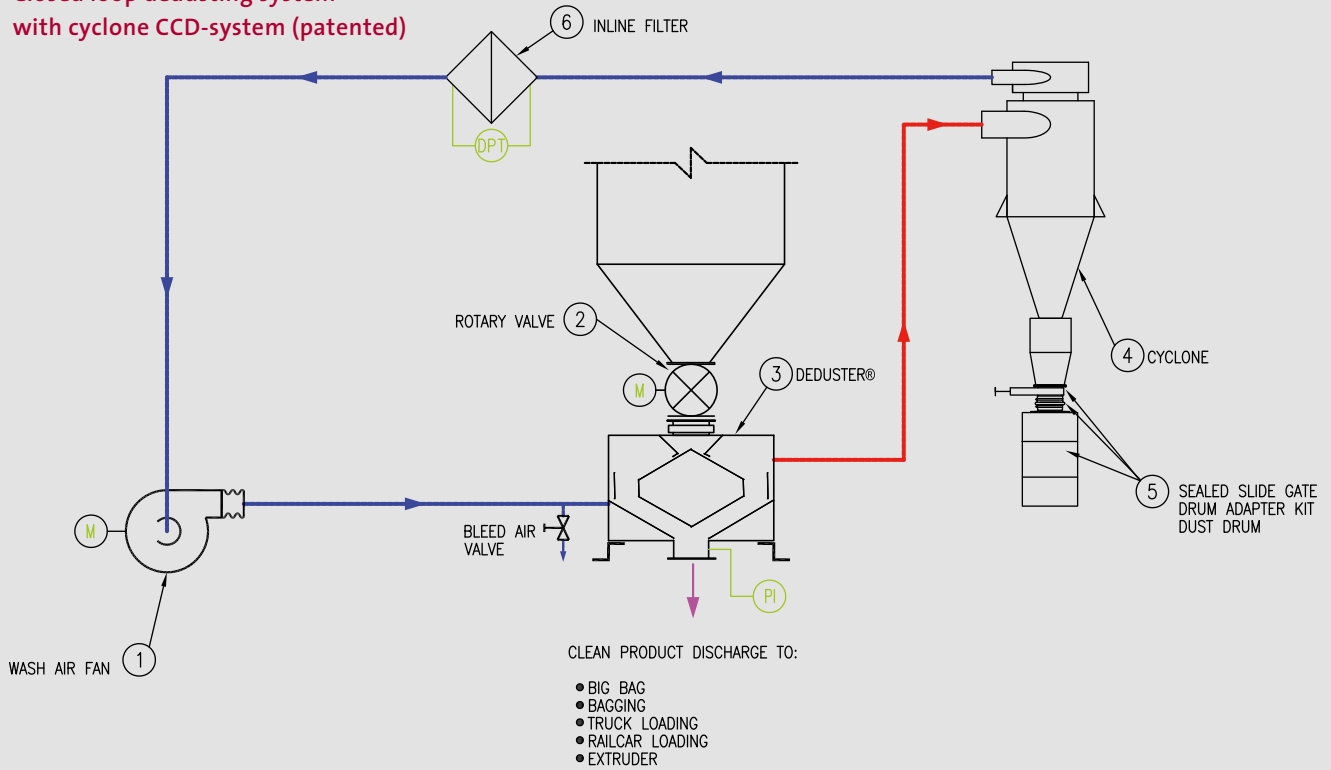

As an alternative to a baghouse, there are also Compact Cyclonic DeDuster® (CCD) systems available, a closed loop application solution with a cyclone and an inline filter. The dust is separated by the cyclone and dropped into a dust container. Remaining fine particles are separated using an inline filter. The cleaned air is returned to the fan.

DeDuster® systems are available in open loop and closed loop versions, as well as in configurations for air tight systems with inert gas or clean room applications. Wash down versions for wet cleaning are also available upon request.

Closed loop dedusting system with baghouse filter

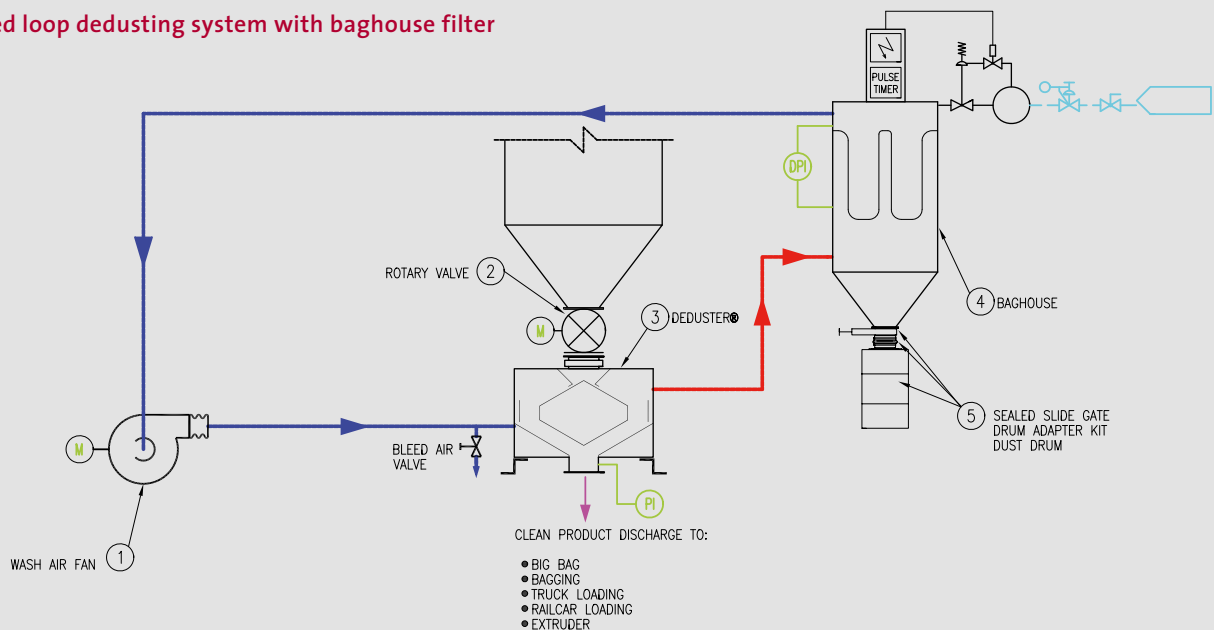

Selecting the Right Dedusting System

To aid in the selection of the best dedusting solution, a free-of-charge dedusting test at the Pelletron test lab is suggested. Once the type and quantity of fines present is determined, a suitable DeDuster® configuration can be recommended. For the very fine dust created in dense phase systems or for high dust volumes, a dust collector with bags is usually the best solution. For systems with coarse dust, typical after dilute phase or regrind operations, a cyclone with an inline filter is the preferred technology. For systems with high streamer content, a cyclone is usually the recommended selection. As a result of testing of over 3,000 kinds of bulk material, Pelletron has the experience to select the proper system configuration to meet any customer requirements.

One of the most important design considerations for a dedusting system is the selection of the fans. Fan sizing is affected by the length, diameter and number of elbows in the duct work, the pressure loss due to filters in the system and the pressure loss and air volume requirements of the DeDuster®. Pelletron engineers take these variables and the properties of the material to be cleaned into consideration when determining the air volume and pressure needed for the best cleaning results.

The manual solution for the air management of a fan is the use of mechanically operated dampers. These dampers are adjusted at start-up and can be readjusted easily in case of product changes. Pelletron also offers variable speed drives for fans which can be operated and regulated from a remote control station. These drives allow for proper system balance and affect energy consumption giving the end-user the ability to manage costs.



Fan with manual damper



HEPA-Filter with door open

Some applications require the use of HEPA-filters, in conjunction with the standard system configuration. Because of the high pressure loss of these filters, the design and selection of the fan(s) becomes even more critical. HEPA-filters are used in clean room applications or for the dedusting of plastic pellets for use in the electronic and optical industries.

Fans, bag house and cyclones for a dedusting system



Dedusting Test Facilities

Pelletron maintains a test lab to provide free-of-charge cleaning tests and detailed digital test reports for customers worldwide. There are two wet test methods established in the market, the European FEM 2482 method and the ASTM Standard D-7486-08. The FEM procedure defines dust content in three classes: Type A from 63 μm to 500 μm , Type B from 45 μm to 500 μm and Type C from 20 μm to 500 μm . The newer ASTM Standard defines the wet test measuring of dust particles from 1.6 μm to 500 μm . Pelletron recommends the use of the ASTM Standard because it covers the entire dust spectrum, including the micro fine dust produced in dense phase systems. For the exact measurement of the dust particles, Pelletron developed the wet test device, tradenamed FineAlyzer®.



FineAlyzer®, Pelletron Corporation's wet test device

Research & Development

Continuous testing has helped to define customer requirements and has led research and development efforts to the creation of the X-Series DeDuster® and the round RC-Series DeDuster®. These new DeDuster® models were targeted at applications that required lower construction height and reduced consumption of cleaning air.

Pelletron believes that creativity is an integral part of the innovation process. Our engineering and design staffs are all involved in the strategic, creative development of new products. Pelletron understands that every process is different because parameters often vary considerably. In many cases, a ready-made solution is not possible. In close cooperation with our customers, we are able to find the best solution through lab testing in order to achieve the ideal process under their pre-defined conditions.

An example of Pelletron creativity is the development of the mobile DeDuster® system for installation on top of bagging machines. This solution provides the highest flexibility in a silo farm with packing requirements. A 3D drawing of this type of mobile unit is shown on page 15.

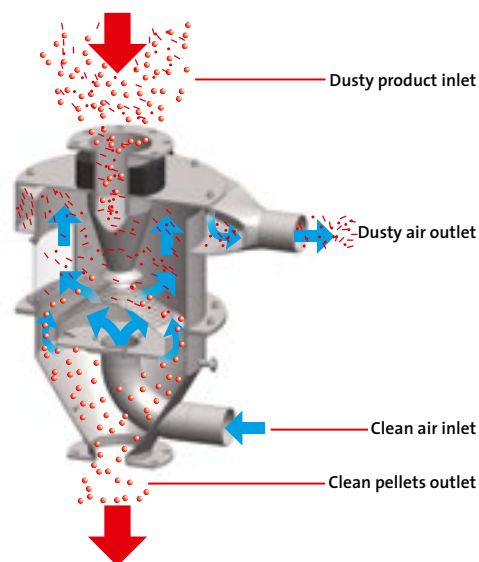

3D model of RC DeDuster®



The new RC DeDuster® in use for lab testing

XP-Series DeDuster®



XP5 is equipped with a single wash deck
XP15 to XP1500 are equipped with double wash decks



XP360 DeDuster with automated inlet deflectors

XP-Series DeDuster® X-tra low height & energy consumption

DeDuster® model	capacity range in lbs/h	in kg/h
XP5	650 – 1,100	300 – 500
XP15	1,000 – 3,500	600 – 1.600
XP45	8,000 – 11,000	3.500 – 5.000
XP90	12,000 – 22,000	5.500 – 10.000
XP180	20,000 – 45,000	9.000 – 20.000
XP360	60,000 – 90,000	27.000 – 40.000
XP540	80,000 – 130,000	36.000 – 60.000
XP720	120,000 – 180,000	54.000 – 80.000
XP900	150,000 – 220,000	70.000 – 100.000
XP1080	200,000 – 260,000	90.000 – 120.000
XP1500	260,000 – 350,000	120.000 – 160.000

DeDuster® models XP180 to XP1500 can be equipped with an automated inlet deflector. The inlet deflectors distribute the material evenly over both wash decks and are designed to regulate the material flow or shut it down completely. This option eliminates the need for the installation of a separate feeding device.

Note: Selection of the DeDuster® model depends on the bulk density of the product being cleaned, the shape of the pellets and the type and quantity of the fines.

P-Series DeDuster®

For special applications with light weight bulk densities such as recycling, food, non-food we recommend using a single deck DeDuster® of the P-series. Available in sizes P10 to P400 for capacities up to 45,000 lbs/h (20.000 kg/h).

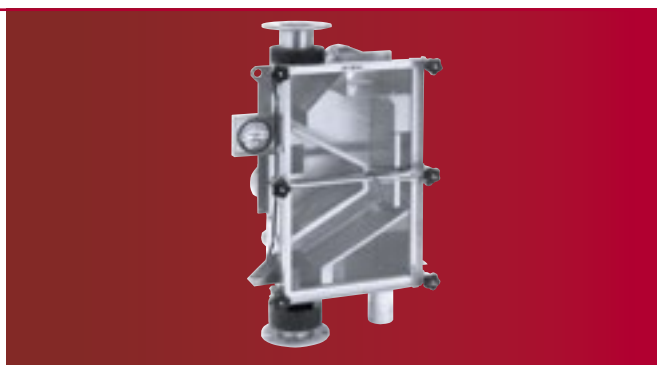

RC-Series DeDuster®

The RC-Series offers low height DeDuster® options designed for a wide range of products with capacities up to 100,000lbs/hr (90.000kg/hr). The round design allows for a reduction in height and lower energy consumption. The larger sizes are available upon request.

DeDuster® type	capacity range in lbs/h	in kg/h
RC1	10 – 750	5 – 350
RC20	3,000 – 5,500	1.500 – 2.500
RC45	9,000 – 11,000	4.000 – 5.000



C-20 DeDuster®

The lightweight C-20 DeDuster® weighs 20 lbs (9 kg) and requires only 9.5 in (240 mm) for installation between the hopper loader and inlet hopper of an injection molding machine. It features stainless steel construction, 110 or 220V operation and only consumes 2-3 CFM (3.4-5 m³/hr) compressed air at 20-30 psi (1.5 – 2 bar) pressure. Cleaning capacity up to 50 lbs/h (20 kg/h), depending on the bulk density.



OS-Series

This DeDuster® has an offset inlet/outlet design. It can be used for applications with inclined piping or other configurations that require an offset design. Various sizes are available. Others can be designed based on unique customer requirements.



DO-Series

This DeDuster® has a single inlet and a dual outlet. It can be used for special applications where narrow or shallow packaging machines are installed or for other configurations that require a dual design. Large sizes are available for railcar and truck loading, equipped with automated inlet deflectors.

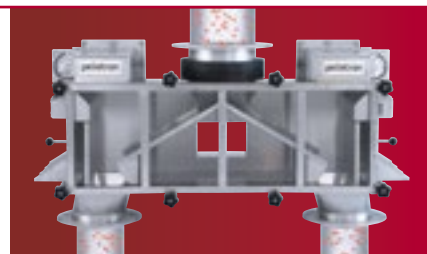

Mobile DeDuster® Systems

Any DeDuster® system can be supplied as a mobile unit. Mobile units can be installed on rails, on a mobile stand or installed on a bagging machine.



Wear-Resistant DeDuster®

For high abrasive bulk materials, a wear resistant DeDuster® is necessary. All DeDuster® types can be supplied in wear resistant versions.



Polished DeDuster®

For special, high grade resins, mirror polishing of the DeDuster® is required (buffing 400). All DeDuster® types can be supplied in polished versions.

Wash Down DeDuster®

Wash down configurations are available for most DeDuster® types. The design allows the cleaning with water and easy access to all areas of the DeDuster®.

Wide Body Design

For some retrofit applications, the available height is not sufficient for the installation of a standard DeDuster®. Pelletron offers a wide body version of its P- and XP - Series in order to reduce the construction height.



It's clean

Pelletron DeDuster® Systems are Installed All Over the World

Pelletron has supplied more than 2,000 DeDuster® systems to companies in more than 50 countries. Pelletron can retrofit solutions for most any type of system configuration due to the wide range of DeDuster® types available. The DeDuster® is the most chosen dust removal system when new plants are designed and built.

Whenever high quality end products are the goal, customers around the world choose the Pelletron DeDuster® to maximize success.

Pelletron Corporation
Corporate Headquarters
1866 Colonial Village Lane
Lancaster, PA 17601
USA

t +1.717.293.4008
f +1.717.293.4011
www.pelletroncorp.com
info@pelletroncorp.com

pelletroneurope GmbH
European Headquarters
Ahornstraße 28
88285 Bodnegg
Germany

t +49.7520.956620
f +49.7520.9566215
www.pelletroneurope.com
info@pelletroneurope.com



pe:etron

Discover **Bulkmatology**®
The Nature of Bulk Material Handling