

OKTOMAT® SOS Classic

Emptying system for Octabin and BigBag

OKTOMAT® SOS Classic	
height	2770 - 3670 mm (7-fold height-adjustable)
width	1520 mm
depth	1160 mm
footprint (suggestion)	1520 mm x 1160 mm
container height	500 - 2170 mm (without extension)
bulk bag tightener stroke	1000 mm
weight	160 to 220 kg
weight with packaging	260 to 320 kg
tension force	2400 N
ambient temperature	0 - 40 °C
electrical connection	230 V, 50/60 Hz 110 V, 50/60 Hz
compressed air connection	min. 6 bar , Ø 13 mm
operation	from the front

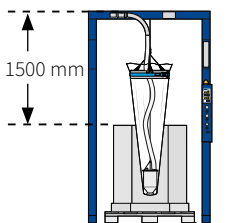

Installation height

The OKTOMAT® SOS Classic is 7-fold height-adjustable. The standard installation height can be selected from 2770 mm - 3670 mm. In order to achieve complete emptying, there must be a minimum distance of 1500 mm between the top edge of the container and the top edge of the discharge station.

Special heights are available as an option.

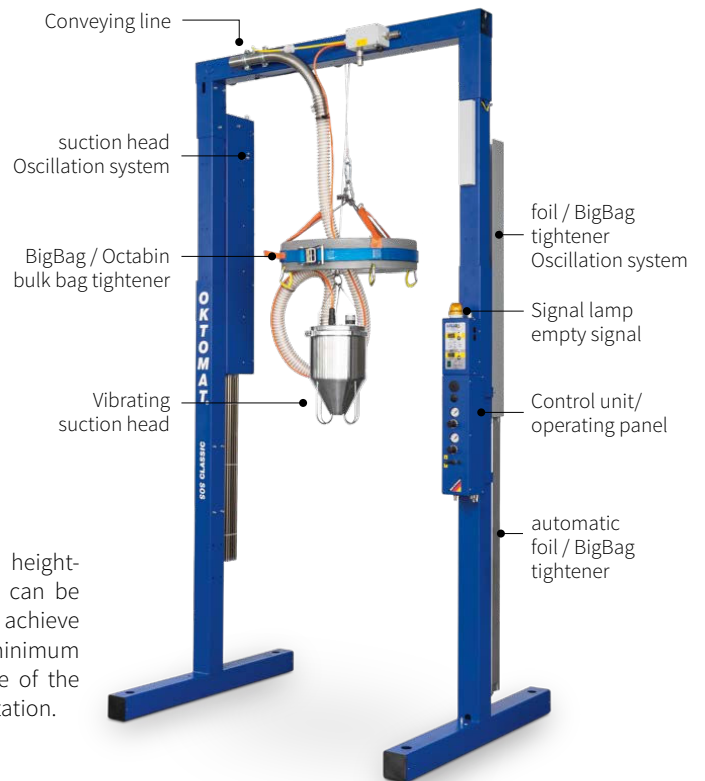

STANDARD EQUIPMENT

Construction

Portal version, particularly space-saving in depth, made of steel, powder-coated

Height

2770 mm - 3670 mm, 7-fold height adjustable, optionally special heights are possible

Foil / BigBag tightener

made of stainless steel (Ø 600 mm) for foil inliners and BigBag

Suction head

Vibrating suction head (electric) type S-38 / type S-45 / type S-50 / type XL

Automatic

Automatic complete emptying by means of automatic bag tightener with 2400 N tension force and controlled lifting and lowering of the suction head.

Conveying line

38 mm / 45 mm / 50 mm
Standard pipe elbow (stainless steel 1.4301 (AISI 304))

SOS system

◆ Oscillating system for suction head

◆ Oscillating system for foil / BigBag tightener

- Residual discharge time display
- Empty signal via LED light and potential-free contact
- Automatic changeover to the next OKTOMAT® (control part)
- Pipe emptying suction (conveying line)

Container types/materials

OKTOMAT® SOS Classic handles easily and effectively the discharging of all common types of Octabins, BigBags, bulk bags with foil inlet. Suitable for emptying of free-flowing to bridge-forming materials.

Delivered pre-assembled in transport box

SOS Classic Control

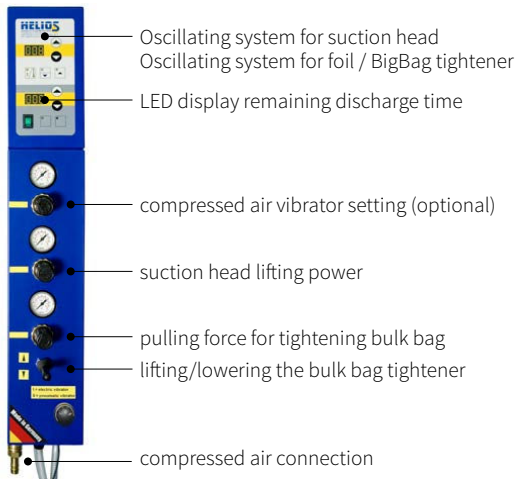

⇨ Oscillating system for suction head

The suction head enters vibrating into the material, is pulled up again in a time-controlled manner (the resulting sinkhole in the material fills up), is lowered back onto the surface and the procedure starts all over again. The oscillation, stroke, lifting force and sequence of short or long strokes are individually adjustable.

⇨ Oscillating system for foil/BigBag tightener

In case of very bridging materials, a non-slip wall may occur during the suction process. By repeated lowering and tightening of the foil / BigBag tightener during suction, the material wall will be loosened, thus enabling the material to flow towards the suction point.

Emptying

In order to be able to empty the pipeline after each conveying process (e. g. in the case of long rising pipes), the suction head is raised above the bulk material level in the container when a signal is received from a conveyor control system and the pipeline is emptied.



SUCTION HEAD

Type	Ø Conveying pipe	Diameter	Vibrator electric	Vibrator pneumatic	ATEX	CLEAN	AK
S-38	38 mm	295 mm	●	○	○	—	○
S-45	45 mm	295 mm	●	○	○	—	—
S-50	50 mm	295 mm	●	○	○	—	○
SM	38 / 45 / 50 / 60 / 65 / 80 mm	295 mm	—	●	○	—	○
XL	38 / 45 / 50 / 60 / 65 / 80 mm	495 mm	●	○	○	—	—
S-80 C	38 / 50 / 65 / 80 mm	250 mm	—	●	●	●	—
XL-80 C	38 / 50 / 65 / 80 mm	450 mm	—	●	●	●	—

● standard ○ optional — not available

Pipe elbows

Standard pipe elbow
stainless steel 1.4301 Ø DN38 | DN45 | DN50
optional:

- Stainless steel pipe elbow (hardened) wear-resistant
- Glass pipe elbow, highly wear-resistant
- straight pipe instead of pipe elbow stainless steel 1.4301 Ø DN60 | DN65 | DN80

Fluidization

For loosening up compacted bulk material. Separate control with two independent pneumatic circuits. Available for suction head SM / XL .

Additional weight

increases the contact weight (+4kg) of the suction head on the bulk material and thus helps to enter into the bulk material. Available for suction head S-38/45/50

Food version

Partial food version for suction head and conveying line (suction head Clean + conveying hose)

ATEX version Zone 2 / 22

partial zone: suction head + conveying line and/or foil/BigBag tightener

OKTOMAT® SOS Classic

OPTIONS / ADDITIONAL EQUIPMENT



① Foil / BigBag tightener



② Foil tightener (ATEX)



③ BigBag tightener (ATEX)

BULK BAG TIGHTENER

Type	Use	Diameter	Fixation	
Foil / BigBag tightener ①	BigBag + foil	260 mm	tension strap + carabiner	○
Foil / BigBag tightener ①	BigBag + foil	400 mm	tension strap + carabiner	○
Foil / BigBag tightener ①	BigBag + foil	600 mm	tension strap + carabiner	●
Foil tightener ②	Foil (ATEX Zone)	600 mm	clamping jaws	○
BigBag tightener ③	BigBag	500 mm	carabiner	○

● Standard ○ optional

Protection cover

Cover for containers + foil / BigBag tightener.
PVC, transparent with zipper
Ø 1200 mm
not suitable for ATEX



ATEX version Zone 2 / 22

partial zone: bulk bag tightener
Available for foil tightener and BigBag tightener

Double station

Automatic switching on to a second container.
Ideal for unmanned shifts. Switchover takes place via pneumatic ball valves. (optional)

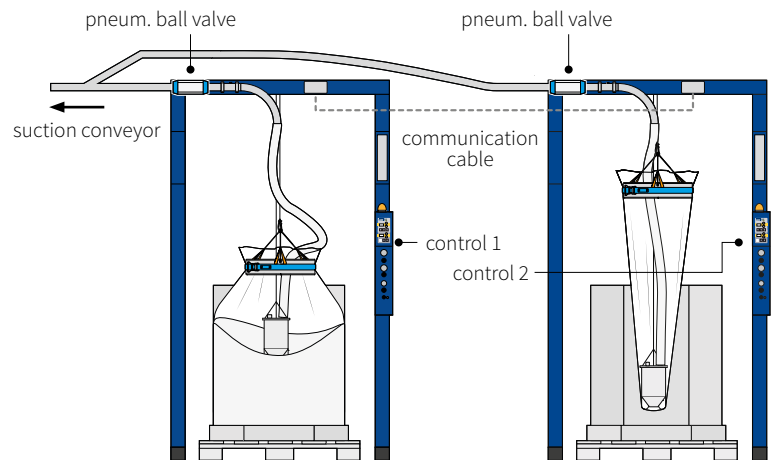

Remote control

For lifting and lowering of suction head and foil / BigBag tightener, start automatic operation. 5m cable length (suitable for standard control)



OKTOBAG® control

The OKTOBAG® control is an extremely comprehensive discharge control and includes

- Graphic display with intuitive operator guidance
- Display of all operating states
- 5 function keys
- Buttons for automatic operation
- Button for conveyor unit ON/OFF

The entire program sequence can be individually programmed and individual functions can be disabled or enabled.



OKTOMAT® SOS Classic

DIMENSIONS

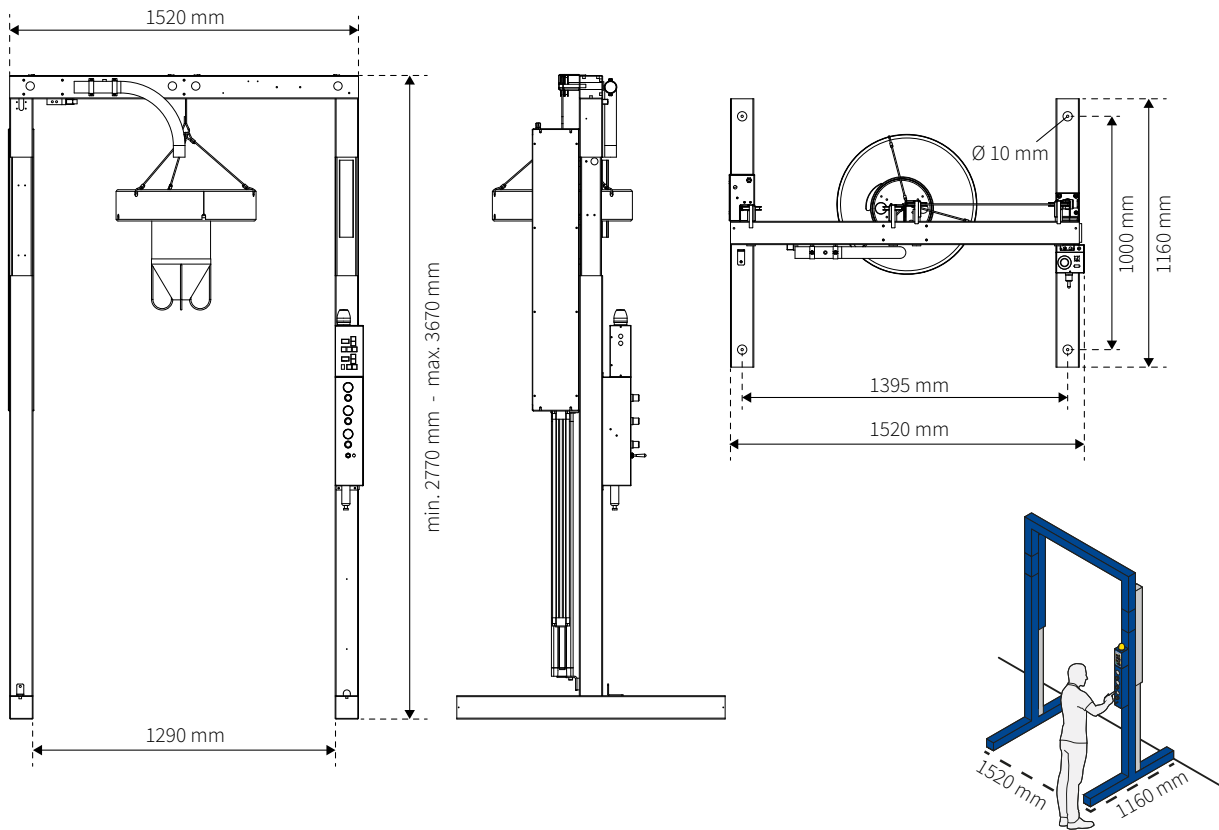

Footprint

The required area to the front depends on the container type used. An area of approx. 1520 mm x 1160 mm is recommended.

Anchoring to the floor

Installation on the floor is carried out with four anchoring dowels (not included).

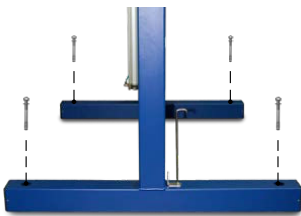

Extension piece

A height of 4270 mm can be achieved by an extension. Rope and cable lengths must be fitted accordingly.

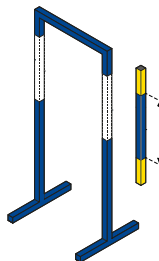

Special width

Special width of 1820 mm for extra wide containers, max. width of container 1500 mm

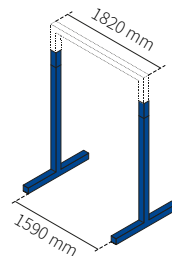

Movable frame on castors

Optional frame with 4 castors incl. fixing bolts. 1500 x 1470 mm.

Height: 155 mm (175 mm when fixed)

Suitable for continuous use.

MADE IN GERMANY



EN_2018_06_18_DB-OKTOMAT SOS Classic | subject to change without notice



HELIOS GmbH - GERMANY
Gerätebau für Kunststofftechnik

Hechtseestraße 8
83022 Rosenheim

info@helios-systems.com
www.helios-systems.com

Tel +49 (0)8031 35418-0
Fax +49 (0)8031 35418-60